

EFFLUENT TREATMENT PLANT

- VOC control for tank breathing and filling
- Meets regulatory air requirements for effluent treatment system
- Redundant system allows overlap for maintenance and optimal uptime
- Uninterrupted service and operation through instrumentation and controls
- Safety devices/scheme incorporated
- Serves customer selected source “tanks”
- Proven constant emission limit compliance
- Threat of fires, overheating, plugging, all mitigated for improved operation and lower likelihood of downtime
- Engineering and equipment supply

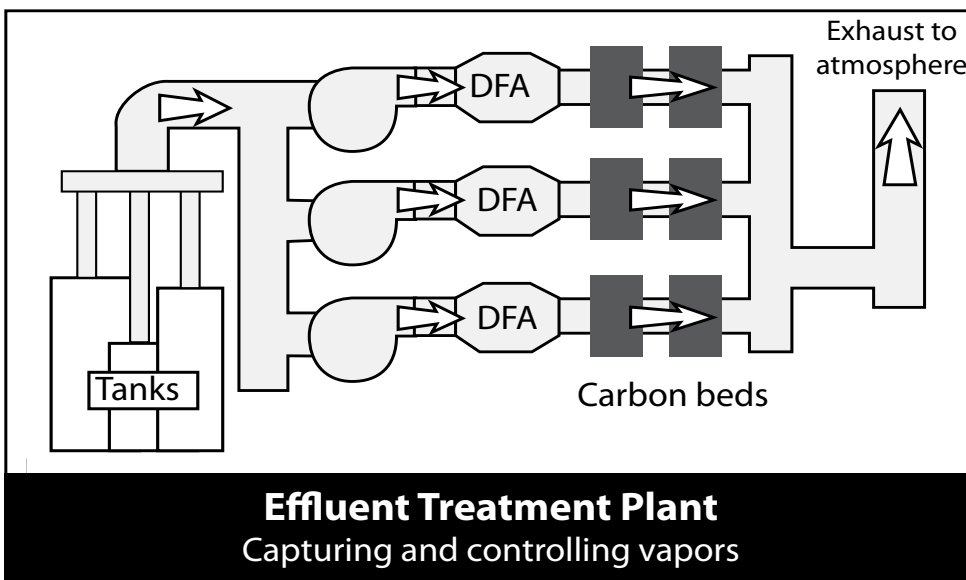

WWW.NACAHTeCH.COM

info@nacahtech.com
412-833-0687

